

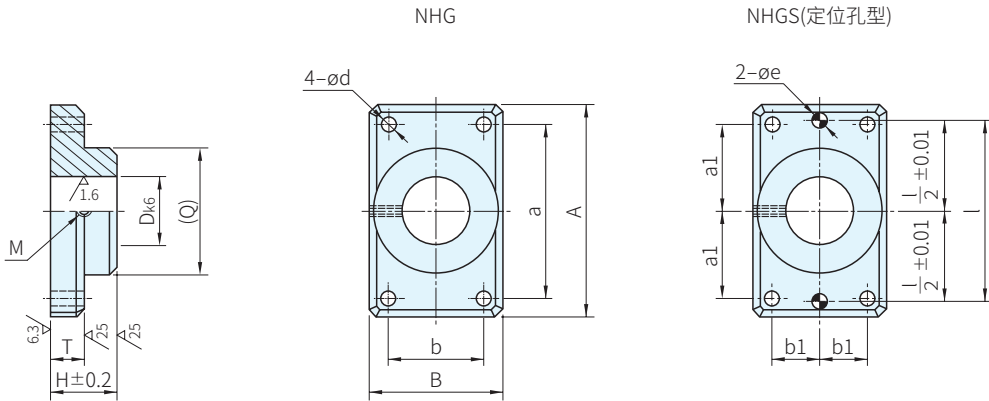

材質
FC250



品號		A	B	a	b	d	H	T	(Q) 參考值	M	e H7	l	a1	b1	庫存		
TYPE	D k6																
NHG NHGS	20	+0.002 -0.011	74	44	56	30	6.6	30	15	42	8	6	+0.012 0	56	28	15	△
	25		84	48	66	30	9	30	20	46		8	+0.015 0	66	33	15	△
	32		100	58	76	36	11	40	20	56		8		76	38	18	△
	38	+0.003 -0.013	130	75	100	44	11	50	25	73	10	100		50	22	△	
	50		155	90	125	60	14	65	25	87	10	125		62.5	30	△	
	60	+0.004 -0.014	190	120	150	80	18	75	30	117	12	13	+0.018 0	150	75	40	△
	80		230	150	180	110	22	100	35	145		16	190	90	55	△	

PS. 備註

· 自行裝配時，請用油壓機壓入

訂貨： 交期：

NHG20